

JUMBO 30

VACUUM PACKAGING MACHINE



FEATURES

- Standard with 1 seal bar (front): 350 mm
- Standard double seal (two wires).
- Optional without extra costs:
Cut-off/Wide seal
- Seal bars easily removable for cleaning and maintenance purposes
- Pump capacity: 8 m³/h Busch vacuum pump
- Pump maintenance and cleaning program
- Machine cycle: 25-60 sec
- Standard Time control with a 1 program memory
- Deep drawn stainless steel vacuum chamber
- Stainless steel exterior and transparent lid
- Comes with insert plate for a faster cycle and product adjustment

OPTIONS

- Sensor control

ACCESSORIES

- Inclined insert plate (for packing liquids)
- Food container adaptor
- Service kit for standard maintenance
- Trolley with shelf

DESCRIPTION

The robust, stainless steel Jumbo 30 vacuum packaging machine is standard equipped with a Busch vacuum pump and Time control with a 1 program memory. This table-top model complies with CE standards.



Henkelman offers standard 3 year warranty

SEAL BAR CONFIGURATION

Standard



VACUUM PACAGING MACHINE JUMBO 30 – SPECS

VACUUM PACKAGING MACHINE JUMBO 30 – SPEC SHEET

DIMENSIONS

In mm

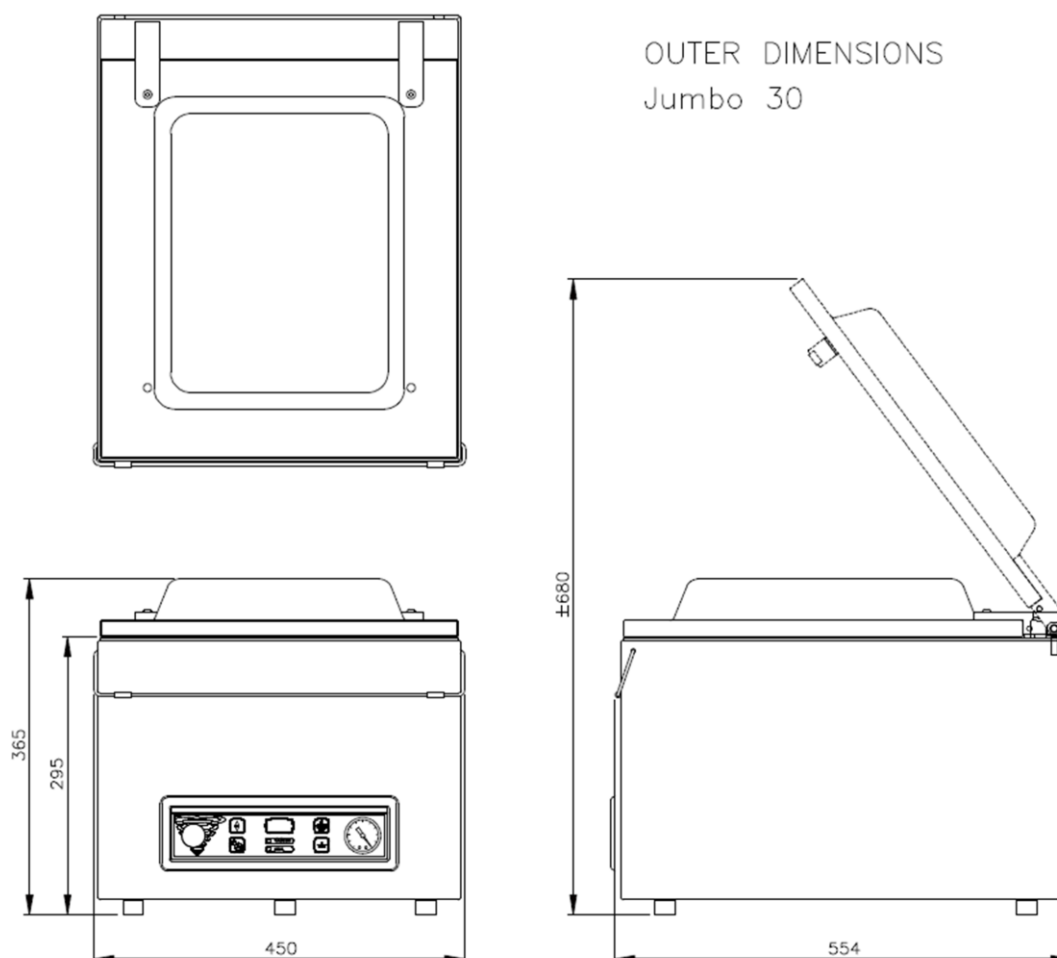

OUTER DIMENSIONS
Jumbo 30

| Model | Dimensions (mm) | | Voltage* (Hz) | Pump capacity (m ³ /h) | Power (kW) | Weight (kg) |
|----------|--|----------------------|------------------|---|---------------|----------------|
| | Chamber (usable space) L x W x H | Machine L x W x H | | | | |
| Jumbo 30 | 370 x 350 x 150 | 554 x 450 x 365 | 230V-1-50 | 8 | 0,4 kW | 44 |

* Other voltages available



HENKELMAN BV
Titaniumlaan 10
5221 CK 's-Hertogenbosch
The Netherlands

Sales support
P +31 73 621 36 71
E info@henkelman.com
Service/technical support
P +31 73 621 36 71
E service@henkelman.com